

Throw more
throw quick



● Trailer-mounted Concrete Pump PMP 40 D

Apollo
CONCRETE SOLUTIONS

Trailer-mounted Concrete Pump PMP 40 D

Technical Specification			
Data	Units	PMP 40 D	
Type of Valve Technology		Flat Gate Valve	
Prime Mover Capacity	KW / HP	48.6 / 66	
Ideal Speed	RPM	2100	
Del. Cylinder Stroke / Dia	MM	1200 X 180	
Displacement / 2 Cylinders	Litres	61	
Diff. Cylinder Stroke / Dia	MM	1200 X 100/55	
Diff. Cylinder Drive		Piston Side	Rod Side
Max. Strokes / Minute		18	25
Max. Theoretical Output	M ³ / Hr	32	45
Max. Hydraulic Pressure	Bar	280	280
Max. Concrete Pressure	Bar	76	60
Max. Vertical Placement	Mtr.	90	80
Max. Horizontal Placement	Mtr.	380	300
Hopper Capacity	L	600	
Del. Line Size*	MM	125	
Dead Weight	Kg.	2900	

* Note: Delivery line 150 mm can be used for 40 mm aggregate pumping but the efficiency level will come down by 40%

Salient Features

- Only manufacturer to give high / low pressure options in gate valve operated concrete pumps
- All wear parts like control housing, siamese pipe, connection pipe and taper pipes are made out of single piece casting of high wear resistance work hardening material, to ensure long life
- The maintenance free hydraulic cylinders are controlled by an integrated controller to ensure highest performance with minimal heat losses

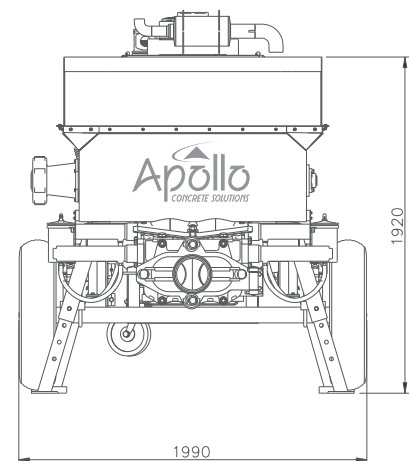
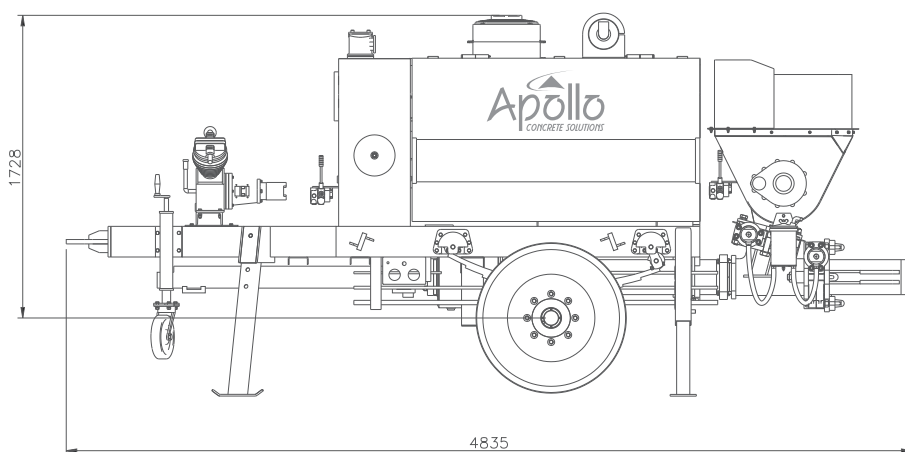

- With Apollo's policy of constant upgradation of products, specifications are subject to change without prior notice.
- Accessories shown here are optional and not the part of standard supply.



Apollo Infratech Private Limited

Ahmedabad-Mehsana State Highway, Village: Rajpur 382740,
Taluka: Kadi, Dist: Mehsana, Gujarat, INDIA
Tel: +91 2764 232217, Fax: +91 2764 233117,
E-mail: sales@apolloinfratech.com

www.apolloinfratech.com